

PROXXON

PROXXON
MICROMOT
System

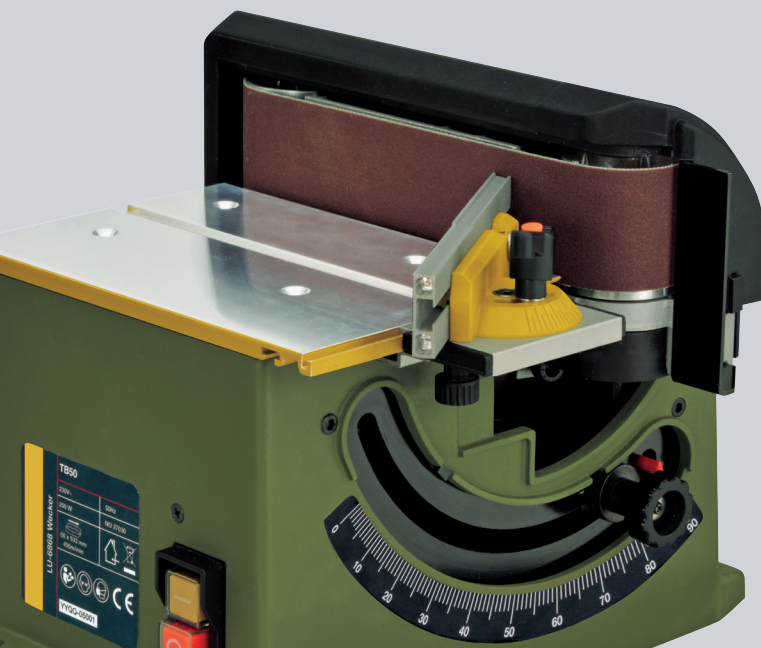

Tools with character!



New products 2022

Table belt sander TB 50. The smallest and finest in the world!

PROXXON
MICROMOT
System

- For fine sanding work and most minute correction.
- Dust-free, clean working due to highly effective extraction.
- Sanding speed of 400 m/min.



Sturdy, plane-milled table
made of die-cast aluminium
(210 x 145mm).

Sanding belt tilting through 90°.

Sliding angle stop for
single- and double mitre cuts.

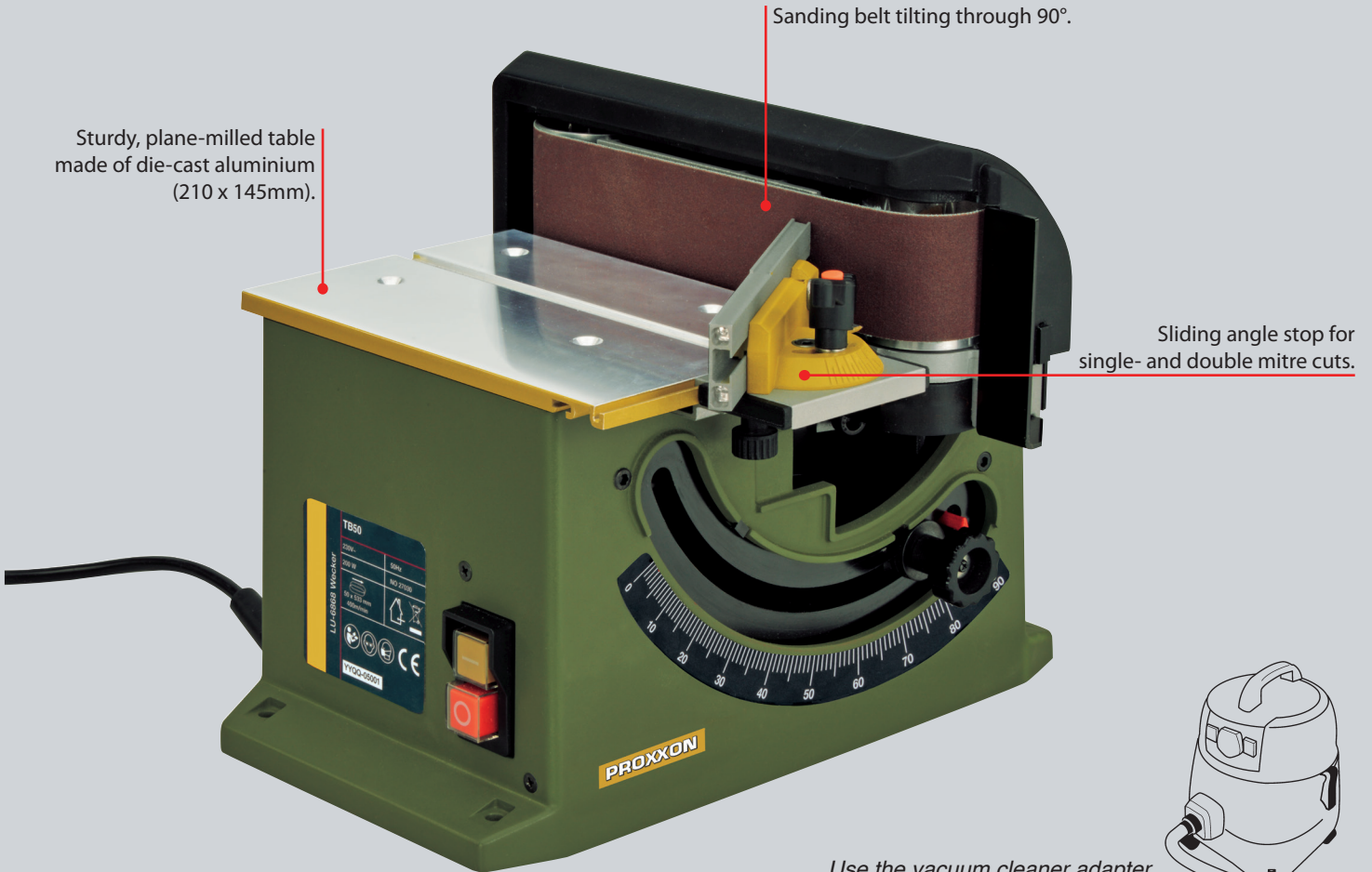

Support table for
contact sanding.

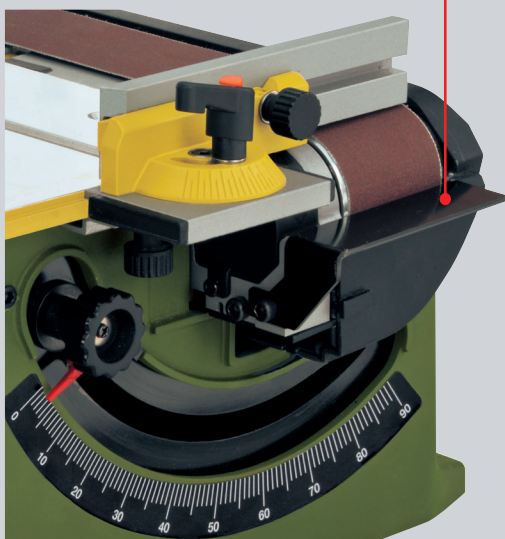

Use the vacuum cleaner adapter
to keep your work area cleaner.

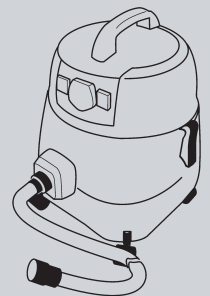

Sands long edges, end sections, radii, mitres, and, by turning the workpiece over-accurate flat surfaces at right angles.

Used on soft and hard woods, non-ferrous metals, steel, plastics (perspex and PC cards) and cork. Powerful drive thanks to balanced DC-motor. Easy replacement of bands without need for tools as rollers are under spring tension. Fine adjustment of rollers prevents the belt from lateral roll-off. Housing is made of glass-fibre reinforced POLYAMIDE: The compact and light design allows stowing away easily after work is done. Suction channel with adapter to connect a vacuum cleaner.

Technical data:

230V. 50/60Hz. Sanding speed 400m/min. Belt dimensions 50 x 533mm. Size 250 x 200mm. Height 250mm. Weight approx. 5kg.

NO 27 030



Tungsten electrode sharpener ESV

For quick and precise sharpening of TIG electrodes. For perfect welding seams.



Note:
Cordless professional drill/grinder IBS/A is not included in the scope of delivery.

Uniform longitudinal grinding ensures high arc stability.

For tungsten electrodes of apex angles of 30° and 60° with diameters of 1,6 – 2 – 2,4 – 3.2mm. Easy preselection thanks to movable guiding element (hard-anodised). Including two diamond-plated grinding discs for low roughness.

NO 28 614

Suitable for the following machines with MICROMOT standard 20mm-collar:

- **NO 29 800** Cordless professional drill/grinder IBS/A
- **NO 28 481** Professional drill/grinder IBS/E
- **NO 28 485** Long neck straight drill/grinder LBS/E
- **NO 28 472** Precision drill/grinder FBS 240/E
- **NO 28 440** MICROMOT 230/E
- **NO 28 500** MICROMOT 60 series

3 new cordless power tools - Made in Europe. Problem solvers for crafts and industry!

Cordless jig saw STS/A

Mobile version of our proven jig saw STS/E (NO 28 530).

Ideal for fine curve cuts in wood up to 12mm, composites up to 5mm, and non-ferrous metal up to 3mm. Variable stroke rate control from 2,000 – 4,500/min. Complete with four Supercut saw blades, lithium-ion battery Li/A2 and rapid battery charger LG/A2.

Technical data:

10.8V. 2.6Ah. Length 270mm. Weight 940g (incl. battery).
NO 29 855

Cordless jig saw STS/A

Including accessories as described above, but without battery and rapid charger. Packed in a cardboard box.

NO 29 857

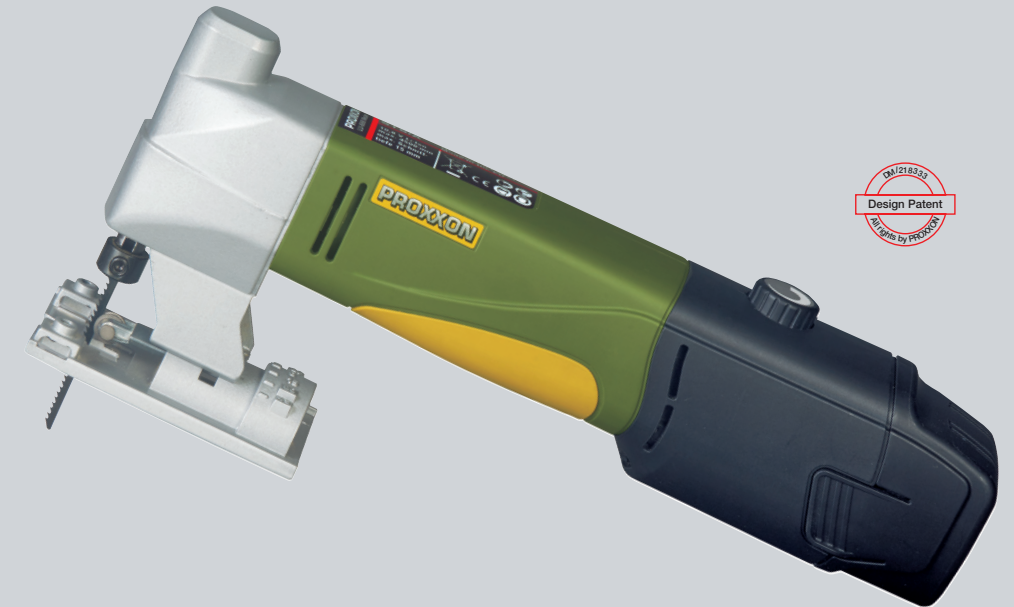

Cordless precision die grinder LGS/A

For use of tool with 6mm of shaft diameter.

Head of die-cast aluminium with 75mm long spindle neck, thus ideal for internal grinding and the use in slots and channels. Performance in a compact design: with only 800g significantly lighter than standard-sized die grinders. Tool holder multiple range collets type ER 11 (6mm collet included). Complete with corundum grinding bit (36 grit), lithium-ion battery Li/A2 and rapid battery charger LG/A2.

Technical data:

10.8V. 2.6Ah. 7,000 – 23,000/min. Length 345mm. Weight 800g (incl. battery).
NO 29 860

Cordless precision die grinder LGS/A

Including accessories as described above, but without battery and rapid charger. Packed in a cardboard box. Ideal for use in the Basic set LBX/A for cordless tools.

NO 29 862



Cordless industrial straight grinder IGS/A

For powerful work at low speeds!

For brushing, grinding, frosting, deburring and paint stripping with 6mm shaft tools. Smooth-running planetary gear in die-cast aluminium housing. Key type drill chuck in industrial design for shafts from 0.5 to 6.5mm. Includes a steel brush (50 mm), an additional handle for stable guidance of tool, lithium-ion battery Li/A2 and rapid battery charger LG/A2.

Technical data:

10.8V. 2.6Ah. 1,500 – 4,200/min. Length 290mm. Weight 970g (incl. battery).
NO 29 850

Cordless industrial straight grinder IGS/A

Including accessories as described above, but without battery and rapid charger. Packed in a cardboard box. Ideal for use in the Basic set LBX/A for cordless tools.

NO 29 852

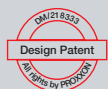

Basic set LBX/A for cordless tools. In proven L-BOXX-system.

Extremely flat L-BOXX complete with two lithium-ion batteries and rapid charger.



Including thermoformed insert for two cordless tools.

Customised selection of two cordless tools for applications such as in metal construction, automotive sector, paint shops, welding, interior work or maintenance. With plenty of space for accessories.

Technical Data:

Rapid charger 100 - 240V. 50/60Hz. Output 12.6V, 2A. Weight 340g. Battery 10.8V. 2.6 Ah. Length 85mm. Weight 180g

NO 29 900

Note:
Two lithium-ion batteries and one rapid charger are included in the scope of delivery.

Individually available cordless tools as Professional drill/grinder IBS/A, Long neck angle grinder LHW/A, Angle polisher WP/A, Random orbital polisher EP/A, Belt sander BS/A, Tube belt sander RBS/A, Foldable screwdriver KS/A, Precision die grinder LGS/A, Industrial straight grinder IGS/A (without storage case, battery, rapid charger) can be combined as needed.





Cordless hot glue gun HKP/A

For fast, reliable bonding of all types of work pieces.

Sensitive mechanical feed. Integrated stand mechanism. With electronically controlled temperature (exactly 170°C) and short heat-up time. Extra-large battery capacity (2.0Ah) for long operation time. Rapid charger with (2.1A) for short charging time of approx. one hour. Including 4 glue sticks Ø 7 x 100mm.



Technical data:

3.6V. 2Ah. 170°C. Weight 200g.

NO 28 190

Replacement glue sticks



For metal, wood, plastic, ceramics, cardboard, leather, polystyrene foams and textiles. Ø 7mm. Length 100mm. Colourless.

NO 28 194

12 pieces

Cordless soldering iron EL/A

For comfortable, mains-independent soldering.

Electronically controlled temperature (470°C) and short heat-up time. Extra-large battery capacity (2.0Ah) for long operation time. Light for illuminating working area. Complete with protective cover, solder and rapid charger with (2.1A) for short charging time of approx. one hour.

Technical data:

3.6V. 2.0Ah. 470°C. Weight 120g.

NO 28 142



Complete with protective cover, solder and rapid charger.



THERMOCUT fence TA 300

Useful addition for the hot wire cutter THERMOCUT 230/E

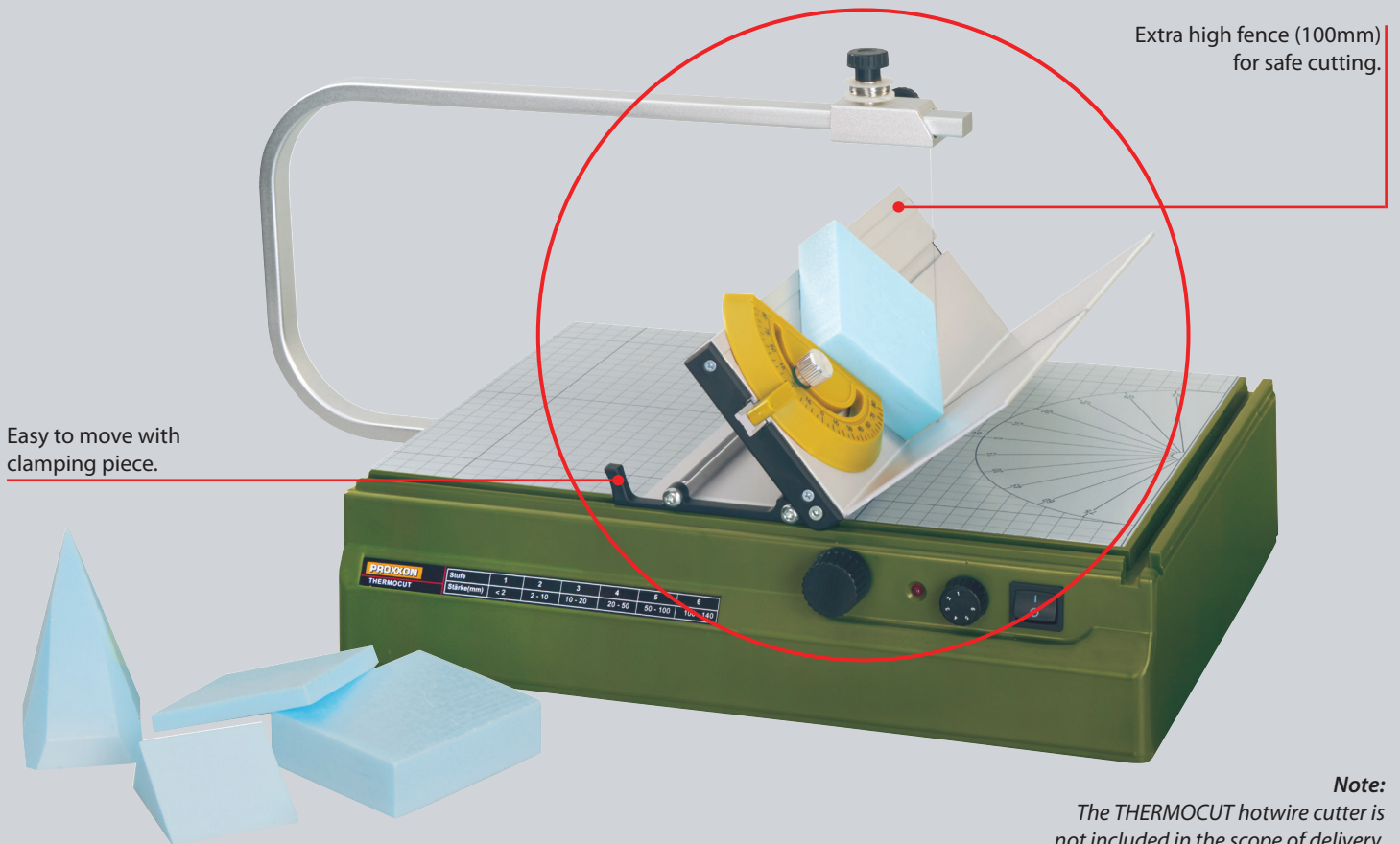

Note:
The THERMOCUT hotwire cutter is not included in the scope of delivery.

For the repeatable and precise production of geometric solids. For safe cutting of high work pieces.

Made of aluminium (finished working surface) for ideal ease of movement. Versatile in use: Freely selectable setting from 0 – 90° for exact angle cuts with high repeat accuracy. Integrated T-slot with additional angle stop for particularly intricate cuts.

NO 27 078

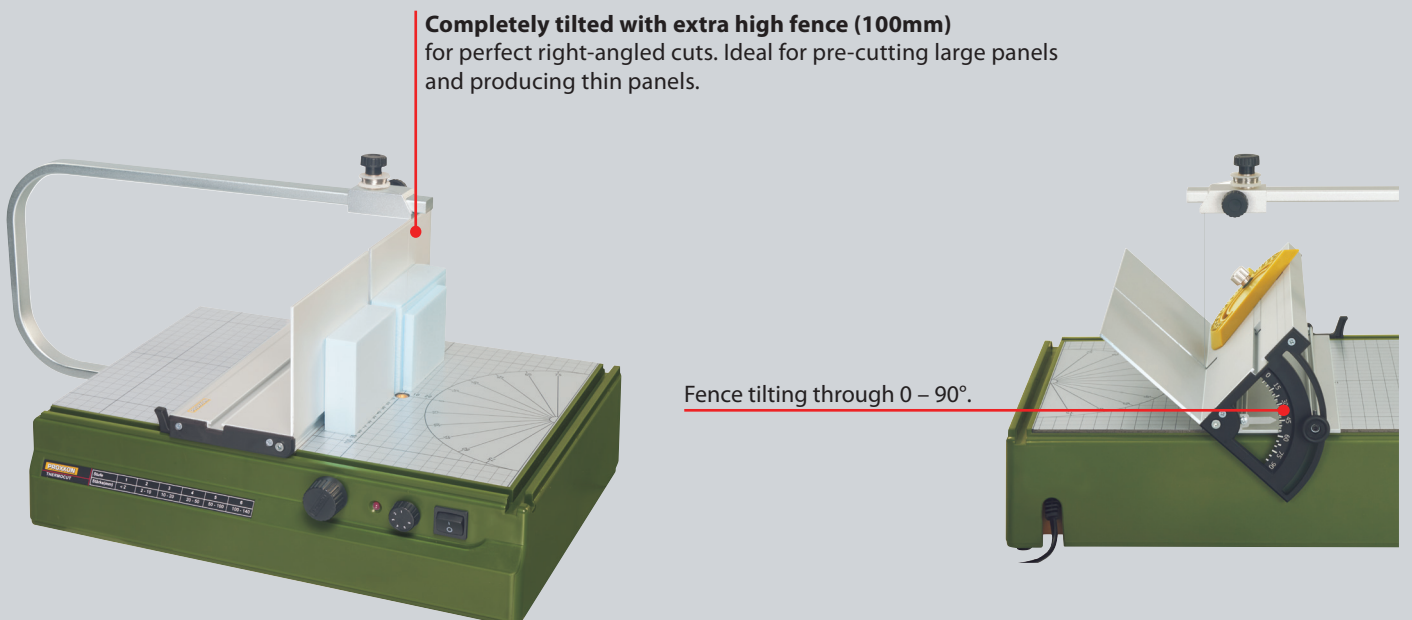

Miller FF 250/BL. Brushless direct drive. Made in Germany.



A high accuracy machining system to mill, drill and bore.

Variable speed pre-selection from 400 – 6.000rpm. Digital speed indication.

230V-operation. The sophisticated control via rotor position and speed sensors guarantees high torque also in the lower speed range. Tool holder using multiple range collets type ER 16 (DIN ISO 15488). One each of 6 – 8 – 10mm are included. Solid plane-milled steel compound table with 3 continuous T-slots.

Technical Data:

230V. 250W. 50/60Hz. Spindle speeds 400 – 6.000rpm. Throat 65mm. Stroke 30mm. Column 35 x 400mm. Table 270 x 80mm. X-travel 170mm, Y-travel 65mm. Dimensions 180 x 130mm. Height approx. 500mm. Weight approx. 17kg.

NO 24 114

Multiple range standard type Typ ER-16 (DIN ISO 15488)

For FF 250/BL and PF 250/BL. One of each Ø 2,4 – 3 – 3,2 – 4 and 5mm. Supplied in a wooden box with sliding lid.

NO 24 146

Fine feed for accurate adjustments during milling for FF 250/BL and PF 250/BL

Quick and easy to install. The clutch system enables feed via either the drill handle or the handwheel. The handwheel has 0.025 graduations and may be set to zero. 1 division = 0.05mm.

NO 24 140



Note:
Clamping jaws, miller and work piece are not included in the scope of delivery.

Mill/drill head PF 250/BL

Converts your lathe PD 250/E or PD 400 into a complete machining centre.

Includes column (Ø 35 x 400mm), mounting bracket and fastening screws (the PD 250/E and PD 400 already come with a plane-milled surface). The lathe's top slide is replaced with the table (supplied) of 110 x 70mm, with 3 T-slots. The lathe now functions as a compound table, with X-Y travel being longitudinally and cross-wise respectively. The mill/drill head is identical to the miller FF 250/BL. Three collets of sizes 6 – 8 and 10mm are included.

NO 24 112

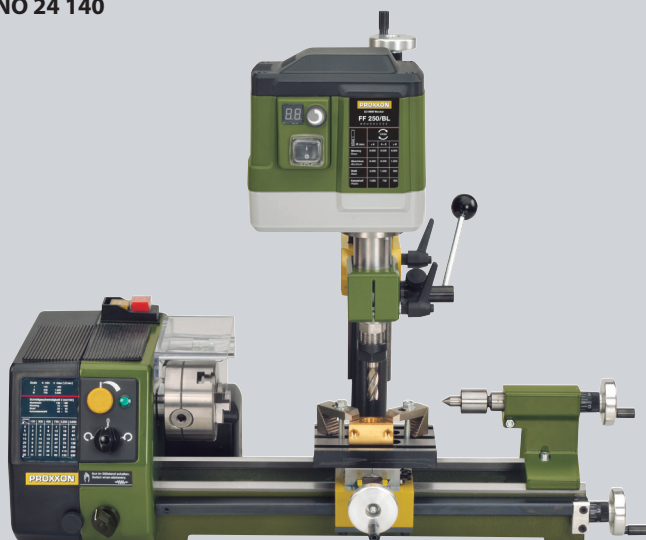

CNC-Control Unit CU 4. For CNC-ready-machines.

- Ready for use, powerful and safe.
- Compatible with MF 70/CNC-ready, FF 500/BL-CNC-ready, PD 400/CNC-ready and for universal use.



For operating CNC lathes and milling machines with up to four axes.

Free choice of CNC-software: e.g. MACH3/4, Estlcam may be used for operation via parallel-port (if necessary with use of LTP-adaptor). Four powerful micro step drivers (norm-interface SUB-D 9-pole) always provide enough energy for any machining processes. One feedback signal (e.g. limit switch) each for each axis.

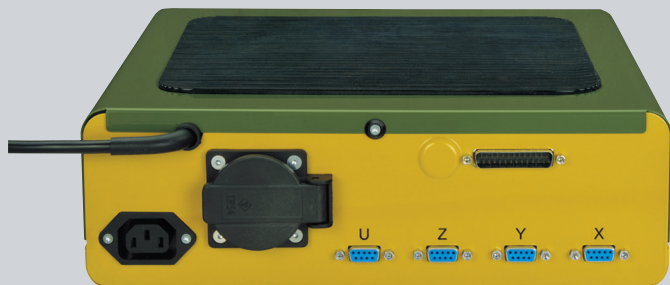

Switching relay for 230V-outlet (IEC-socket and protective contact socket) for spindle powering or special functions up to 2,500W.

Solid main housing made of 1.2mm steel plates (powder-coated) with large grooved rubber mat for tool storage.

Technical data:

230V. 50/60Hz. Dimensions 330 x 300mm. Height 100mm. Weight approx. 4.5kg. Insulated to class 1.

NO 24 900

Precision lathe PD 400/CNC-ready

Axes drive with powerful step motors and recirculating ball spindles (no backlash). For facing and longitudinal turning, for turning balls, radii and any freely formed contours made of steel and non-ferrous metal.

Otherwise, the mechanical design is almost identical to the proven PROXXON lathe PD 400 (see main catalogue page 66/67).

NO 24 504

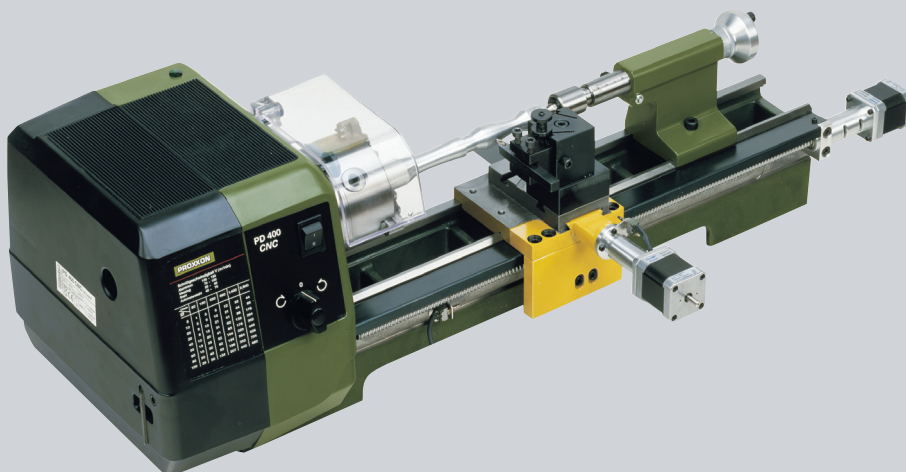

New accessories for our Angle-polishers WP/E and WP/A

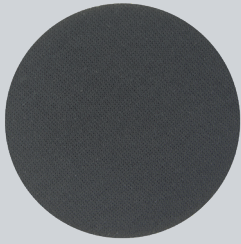

Flexible sanding pads

Self-adhesive type. Adapts precisely to uneven surfaces due to foam body. Silicon carbide with high durability thanks to backing in a net structure (prevents clogging by dust). Ideal for smart-repair, fine sanding and reworking of 3D printed parts. Ø 50 mm.

NO 28 672 K 1000 6 pieces

NO 28 674 K 2000 6 pieces

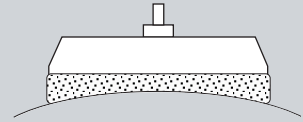

Eraser disc

Used for removal of glue residual, foil or other superficial pollutants. Ideal for removing glue residues from balancing weights on light alloy rims. Ø 50 mm.

NO 29 068

New accessories for our Long neck angle grinders LHW and LHW/A



Coarse cleaning disc

Abrasive fleece, used for cleaning, paint, rust and scale removal of metallic surfaces. For preparation of welding spots. Ø 50 mm.

NO 28 553

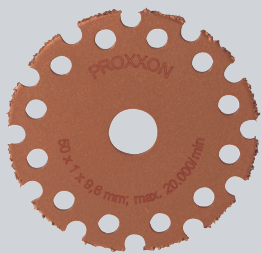

Tungsten carbide cutting disc

Less heating up due to cooling holes. For cutting wood (especially wooden floors) and jointing mortar. Ø 50 mm.

NO 28 556



PROXXON GmbH

Industriepark Region Trier

Dieselstraße 3 - 7

DE-54343 Föhren

Telefon 0 65 02 - 93 17 - 0 • Telefax 0 65 02 - 93 17 - 100

E-Mail: export@proxxon.com • www.proxxon.com